

SUPER MUCKER™

TM

Scavenger Conveyor Cleaning System Pat. Pending

Modular Steel Construction
Available widths 48" - 72"
Available lengths 10 ft. – 30

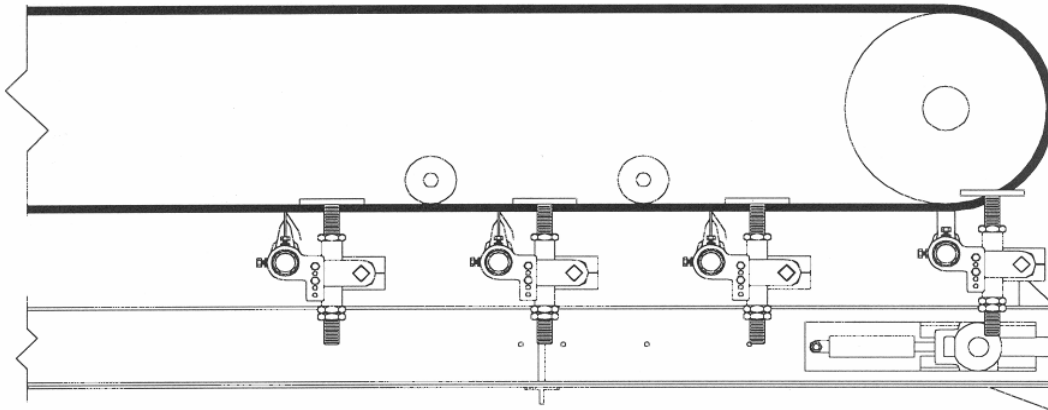

- 5 ft. Modular Bolt Up Sections
- AR-200 Chain Rails & Bottom Pans
- 3.075" 40,000 lb. Drag Chain
- Solid AR-200 Flights
- Grease Jack / Shim Set Take-Ups
- 7-1/2 HP Shaft Mount Drive
- Ease of Transport & Installation
- Extended Wear Life
- Longer Life
- Prevents Flight Bending
- Maintain Proper Chain Tension
- Maximum Machine performance w/ no shear pins

**Baker
Bohnert®**

FEATURES

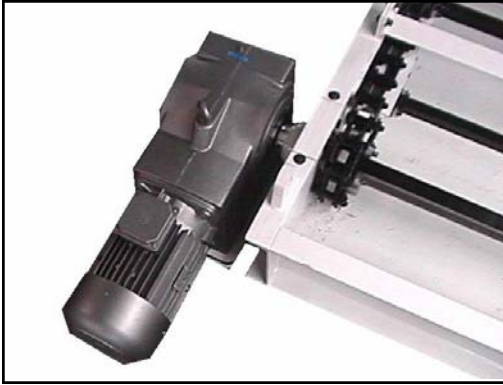

7-1/2 Horsepower Shaft Mount Drive
maximum machine performance
with no shear pins

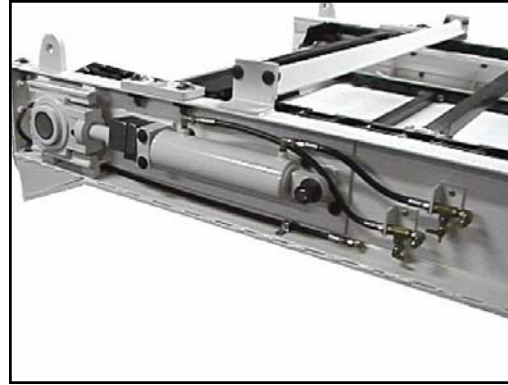

Grease Jack / Shim Set take-ups
maintain proper chain tension and
shaft alignment

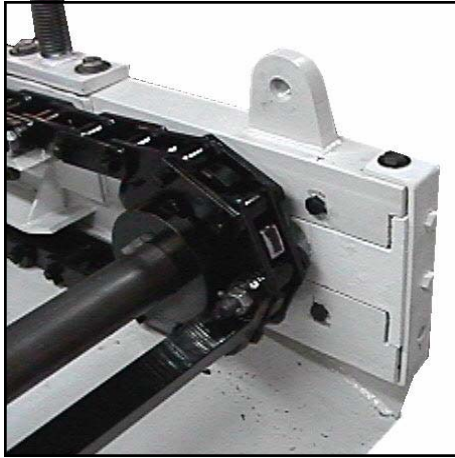

Slotted Siderails for Head
and Tail Shaft removal

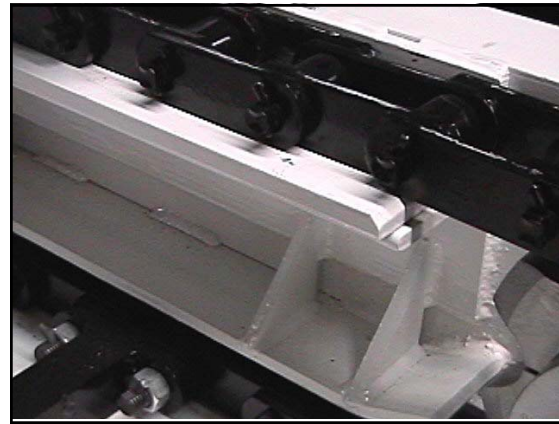

AR-200 Chain rails and bottom deck
for maximum machine life



3.075" Pitch 40,000 lb. chain with
solid AR-200 flights for longer life
and prevents flight bending

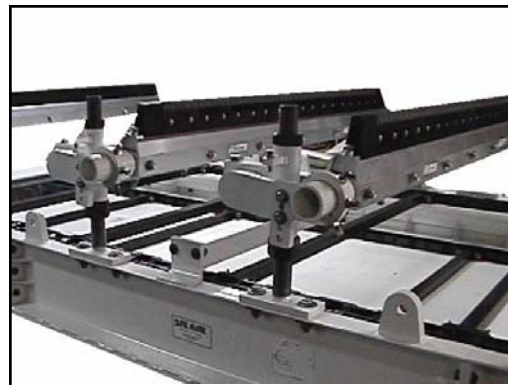

Belt Boss™ Mine Duty Cleaning
Systems for effective cleaning on
high speed mechanical spliced belts

**Baker
Bohnert**

WE PROVIDE SOLUTIONS

1311 Bernheim Lane, Louisville KY 40256

Tel 502-634-3661 Fax 502-634-1090

www.baker-bohnert.com